

Micolux

L I G H T I N G

LIGHTING THE NATION

SINCE 2010



AVIATION OBSTRUCTION LIGHT
FLOOD LIGHT
STREET LIGHT
HIGH BAY LIGHT

 www.micoluxlighting.com

ABOUT US

We are an ISO 9001:2015 & 14001 : 2015 certified manufacturers & exporter to more than 28 countries of **Aircraft Lamps, Aviation Obstruction Light & Commercial LED Lamps and Lights under the brand name of "MICOLUX"**. We manufacture these products using high grade material & components to ensure that these deliver superior performance. The products offered by us are widely appreciated by our clients for their durability, energy efficiency and maintenance free life.

Our industrious professionals work towards offering premium products to the clients. They maintain regular contact with the clients to gauge their exact requirements and ensure that the same are effectively met. We also specialize in customizing our entire range as per the specifications given by our clients. This is why our products find wide usage in all segments of the society, whether it is offices, households, theaters/ cinema halls or hospitals, Wind Turbines, Telecom Towers, Chimneys, Cranes, High Rise Buildings, Factories etc



OUR CERTIFICATIONS

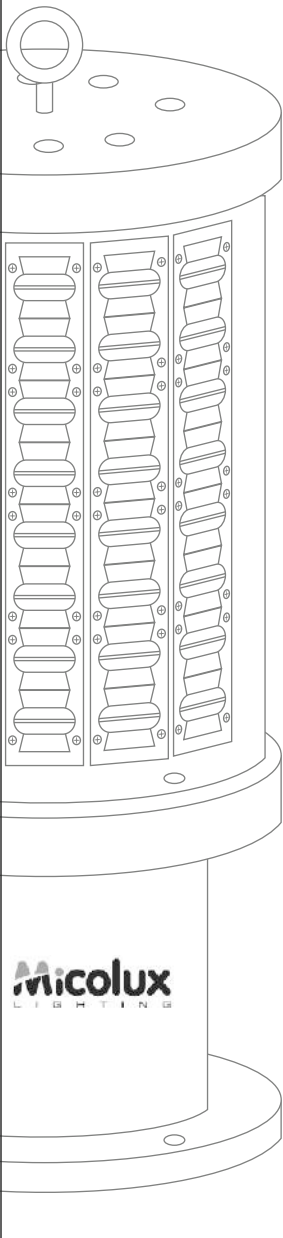
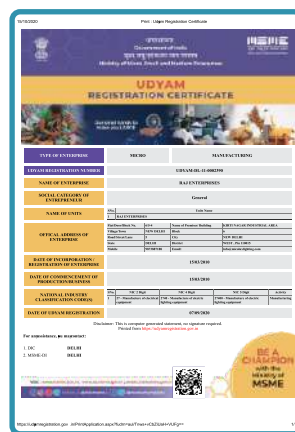

PRODUCT APPLICATION



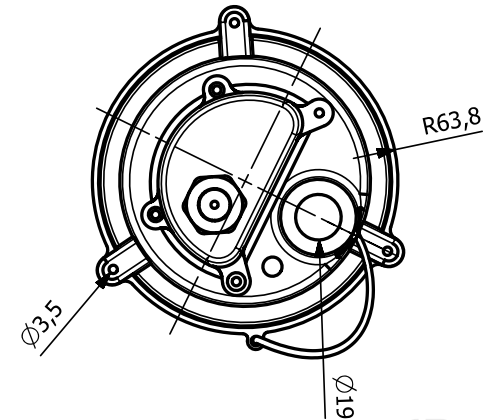
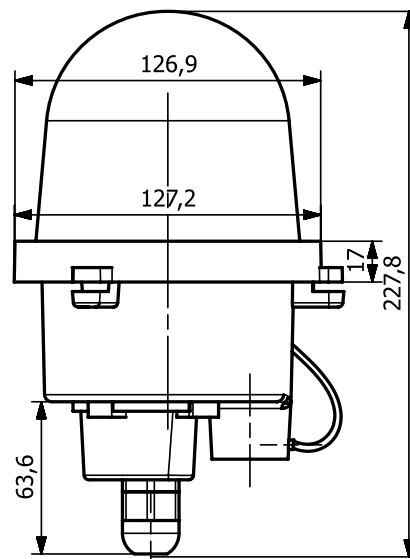

Model No. MLL 904 SLI

SINGLE DOME LOW INTENSITY AVIATION OBSTRUCTION LIGHT

SALIENT FEATURES

- ICAO Type A & B Compliant
- Low Intensity Obstruction Light
- Gives omni directional light
- Protection: Weather proof IP 65
- Material of Base : Cast aluminum (LM 6)
- Glass Type : UV Stablized Red Polycarbonate
- Gasket: Silicone
- Light source: 88 High Bright LED's mounted on glass epoxy Fire Retarded PCBs
- Input Voltage : 85-290V AC or 48V - 85V DC (as per customer requirement)
- Output Voltage : 12V DC
- Wattage – 4W
- Multiple light elements reduce chances of complete blackout due to any unlikely lamp failure
- Approx life of around 100000 hrs
- Luminous Intensity: > 32 CD
- Earthing Terminal: Provided.
- Paint: Aviation Yellow (Epoxy Powder Coated)
- Flashing - Can be done on customer request
- Photosensor - inbuilt for automatic control or separate (as per customer requirement)
- Fault Alarm –Yes (if required)
- Steel wire connected from Base to Red Dome for easy carrying
- Lamp Color : Red
- Lamp Unit Weight : 750 gm.

Micolux
L I G H T I N G

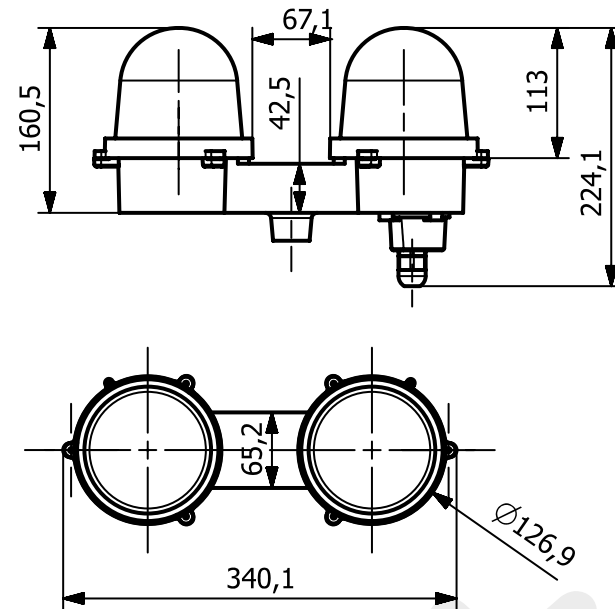

Model No. MLL 905 DLI

DUAL DOME LOW INTENSITY AVIATION OBSTRUCTION LIGHT

SALIENT FEATURES

- ICAO Type A & B Compliant
- Dual Dome Low Intensity Aviation Light
- Gives omni directional light
- Protection: Weather proof IP 65
- Material of Base : Cast aluminum (LM 6)
- Glass Type : UV Stabalized Red Polycarbonate
- Gasket: Silicone
- Light source: 88 x 2 High Bright LED's mounted on glass epoxy PCBs
- Input Voltage : 85-290V AC or 48V - 85V DC (as per customer requirement)
- Output Voltage - 12V DC
- Wattage – 4W
- Multiple light elements reduce chances of complete blackout due to any unlikely lamp failure.
- Approx life of around 100000 hrs
- Luminous Intensity: > 32 CD
- Earthing Terminal: Provided.
- Paint: Aviation Yellow (Epoxy Powder Coated)
- Flashing - Can be done on customer request
- Photosensor - inbuilt for automatic control or separate (as per customer requirement)
- Fault Alarm –Yes (if required)
- Steel wire connected from Base to Red Dome for easy carrying
- Lamp Color : Red
- Lamp Unit Weight : 2.5Kg.

The major advantage of having a twin Aviation obstruction lights is that when the service light fails, the light switches onto its standby lighting system. This eliminates the chance of complete blackout, during an unlikely circuit failure

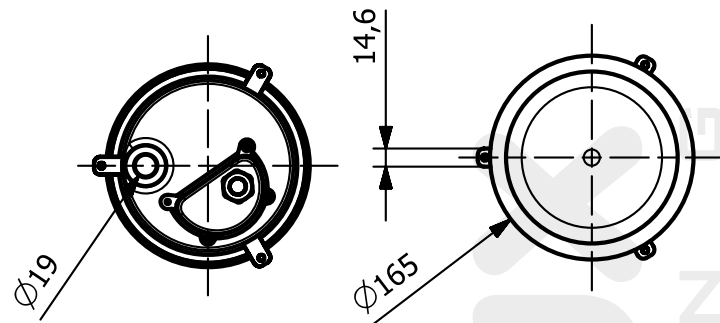
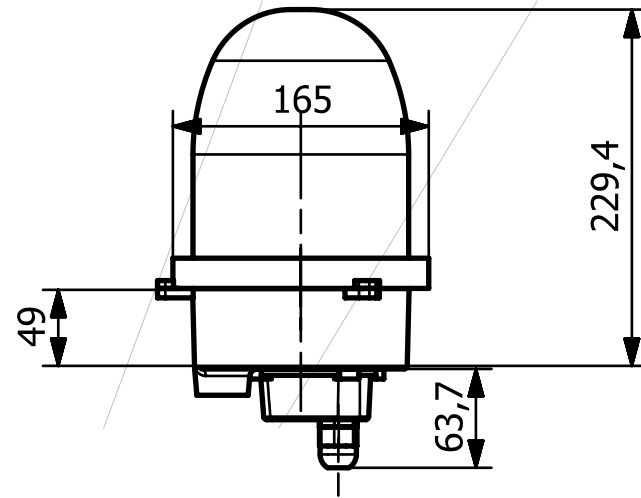

Model No. MLL 904 MI

SINGLE DOME MEDIUM INTENSITY AVIATION OBSTRUCTION LIGHT

SALIENT FEATURES

- ICAO Type B & C Compliant
- Medium Intensity Obstruction Light
- Gives omni directional light
- Protection: Weather proof IP 65
- Material of Base : Cast aluminum (LM 6)
- Glass Type : UV Stabilized Red Polycarbonate or transparent Glass (on customer request)
- Gasket: Silicone
- Light source: 12 Nos. Power LED's mounted on MCPCB with lens & Aluminum Heat sink
- Input Voltage : 85-290V AC or 48V - 85V DC (as per customer requirement)
- Output Voltage : 12V DC
- Wattage – 24W
- Approx life of around 100000 hrs
- Luminous Intensity: 2000 CD \pm 25%
- Earthing Terminal: Provided.
- Paint: Aviation Yellow (Epoxy Powder Coated)
- Flashing –Inbuilt for Type B & Steady for Type C
- Photosensor - inbuilt for automatic control or separate (as per customer requirement)
- Fault Alarm –Yes (in required)
- Lamp Unit Weight : 2.0 kg.

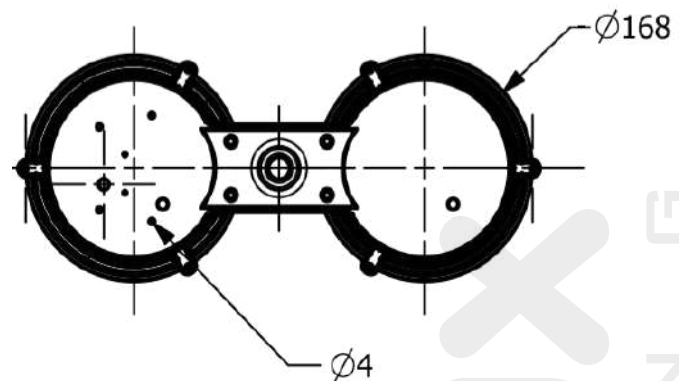
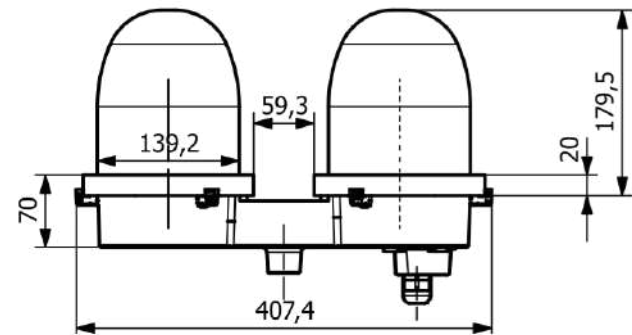

Model No. MLL 905 DMI

DUAL DOME MEDIUM INTENSITY AVIATION OBSTRUCTION LIGHT

SALIENT FEATURES

- ICAO Type B & C Compliant
- Dual Dome Medium Intensity Aviation Light
- Gives omni directional light
- Protection: Weather proof IP 65
- Material of Base : Cast aluminum (LM 6)
- Glass Type : UV Stabalized Red Polycarbonate or transparent Glass (on customer request)
- Gasket: Silicone.
- Light source: 12x2 Power LED's mounted on MCPCB with lens & Aluminum Heat sink
- Input Voltage : 85-290V AC or 48V - 85V DC (as per customer requirement)
- Output Voltage : 12V DC
- Wattage – 24W
- Multiple light elements reduce chances of complete blackout due to any unlikely lamp failure.
- Approx life of around 50000 hrs
- Luminous Intensity: 2000 CD \pm 25%
- Earthing Terminal: Provided.
- Paint: Aviation Yellow (Epoxy Powder Coated)
- Flashing –Inbuilt for Type B & Steady for Type C
- Photosensor - inbuilt for automatic control or separate (as per customer requirement)
- Fault Alarm –Yes (in required)
- Lamp Unit Weight : 6.0 kg.

The major advantage of having a twin Aviation obstruction lights is that when the service light fails, the light switches onto its standby lighting system. This eliminates the chance of complete blackout, during an unlikely circuit failure

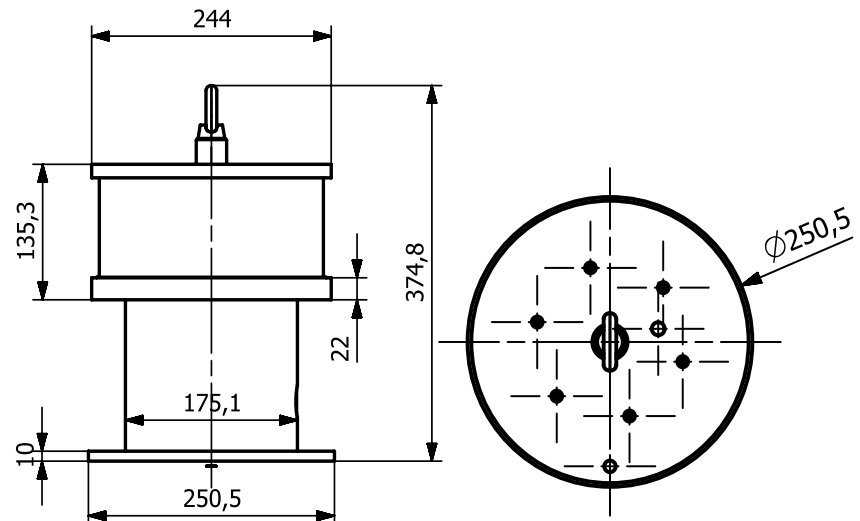

Model No. MLL 906 MI

MEDIUM INTENSITY AVIATION OBSTRUCTION LIGHT

SALIENT FEATURES

- ICAO Type B & C Compliant
- Horizontal Beam Spread 360°/Vertical Beam Spread 3°
- Protection: Weather proof IP 66
- Material of Base : Cast aluminum (LM 6)
- Glass : 6mm Borosilicate Clear Glass
- Gasket: Silicone
- Light source: 24 Nos. Red Color Power LED's with special optics
- Light Intensity : 2000 CD \pm 25%
- GPS Sync / GSM available on request
- Input Voltage : 85-290V AC or 24V - 60V DC (as per customer requirement)
- Output Voltage : 12V DC
- Wattage – 30W
- Approx life of around 50000 hrs
- Earthing Terminal: Provided.
- Paint: Grey/Orange/Yellow (Epoxy Powder Coated)
- Flashing –Inbuilt for type B & steady for type C
- Photosensor - inbuilt for automatic control or separate (as per customer requirement)
- Fault Alarm –Yes (if required)
- Lamp Unit Weight : 12.0 kg.
- Separate Junction Box for wiring.



Model No. MLL 906 MI A / AB / AC

MEDIUM INTENSITY AVIATION OBSTRUCTION LIGHT

SALIENT FEATURES

- ICAO Type A Compliant & Type AB Compliant
- Horizontal Beam Spread 360°/Vertical Beam Spread 3°
- Protection: Weather proof IP 66
- Material of Base : Cast aluminum (LM 6)
- Glass : 6mm Borosilicate Clear Glass
- Gasket: Silicone
- Light source: Power LED's with special optics
- Light Intensity :
 - for Type A - white flashing 20000 cd at day & 2000 cd at night
 - for Type AB - white flashing 20000 cd at day & red flashing 2000 cd at night
 - for Type AC – White flashing 20000 cd at day & red steady 2000 cd at night
- GPS Sync / GSM available on request
- Input Voltage : 85-290V AC or 24V - 60V DC (as per customer requirement)
- Output Voltage : 24V DC
- Wattage – 150W for white light & 30W for Red light
- Approx life of around 50000 hrs
- Earthing Terminal: Provided.
- Paint: Grey/Orange/Yellow (Epoxy Powder Coated)
- Flashing - Inbuilt or through separate control panel
- Photosensor - Inbuilt for automatic control or separate
- Fault Alarm - On customer request (potential free contact)
- Type A : 24 Hrs white Flashing
- Type AB : White Flashing in day, Red Flashing in Night
- TypeAC : White Flashing in day & Red Steady in Night
- Lamp Unit Weight : 12.0 kg.

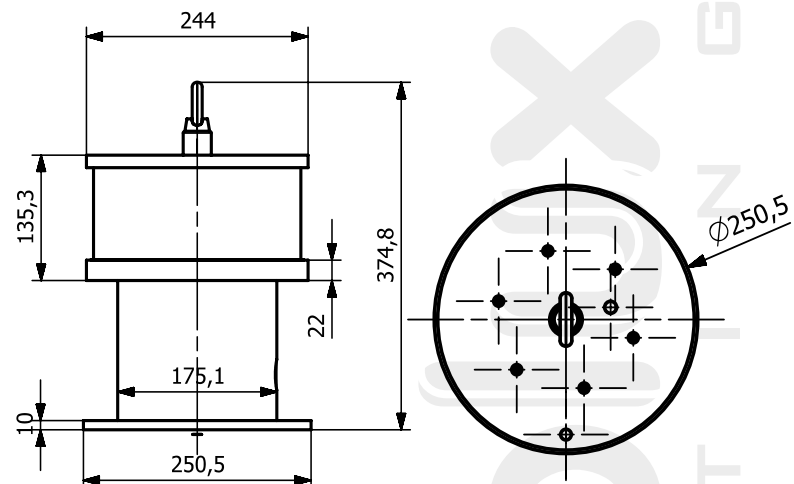



Model No. MLL 906-1 MI A / AB / AC

MEDIUM INTENSITY AVIATION OBSTRUCTION LIGHT

SALIENT FEATURES

- ICAO Type A Compliant & Type AB Compliant
- Horizontal Beam Spread 360°/Vertical Beam Spread 3°
- Protection: Weather proof IP 66
- Material of Base : Cast aluminum (LM 6)
- Glass : Polycarbonate Dome
- Gasket: Silicone
- Light source: Power LED's with special optics
- Light Intensity :
 - for Type A - white flashing 20000 cd at day & 2000 cd at night
 - for Type AB - white flashing 20000 cd at day & red flashing 2000 cd at night
 - for Type AC – White flashing 20000 cd at day & red steady 2000 cd at night
- GPS Sync / GSM available on request
- Input Voltage : 85-290V AC or 24V - 60V DC (as per customer request)
- Output Voltage : 24V DC
- Wattage – 150W for white light & 30W for Red light
- Approx life of around 50000 hrs
- Earthing Terminal: Provided.
- Paint: Grey/Orange/Yellow (Epoxy Powder Coated)
- Flashing - Inbuilt or through separate control panel
- Photosensor - Inbuilt for automatic control or separate
- Fault Alarm - On customer request (potential free contact)
- Type A : 24 Hrs white Flashing
- Type AB : White Flashing in day, Red Flashing in Night
- Type AC : White Flashing in day & Red Steady in Night
- Lamp Unit Weight : 12.0 kg.
- Separate Junction Box for wiring.

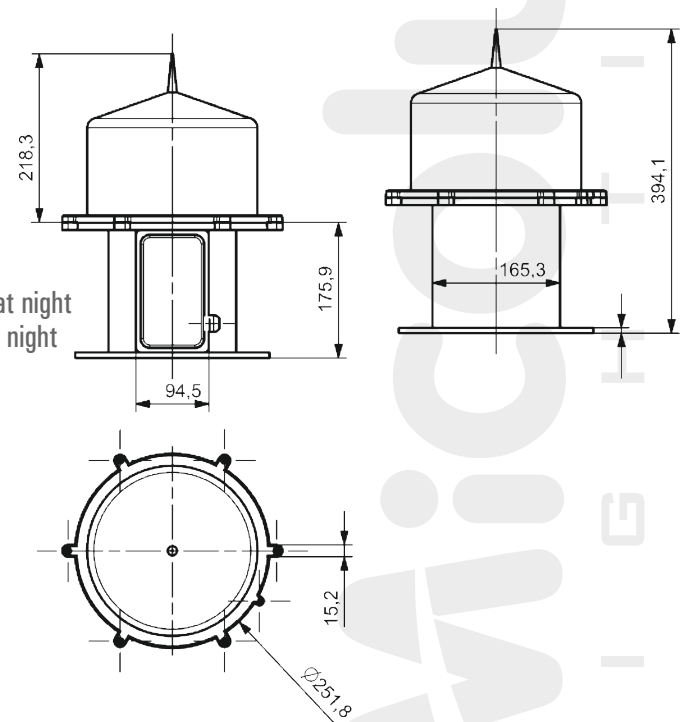

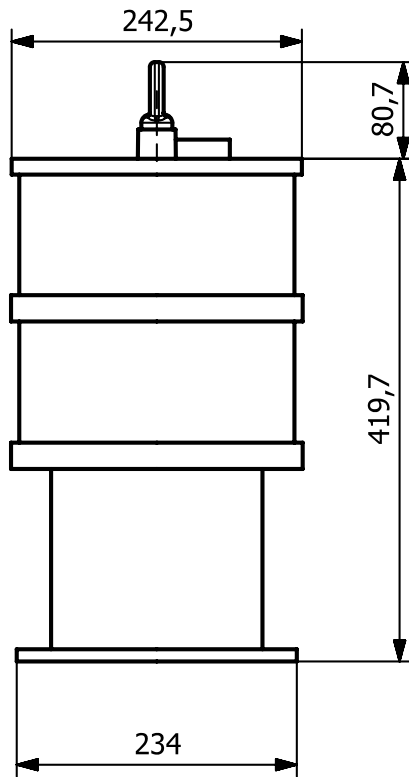

Micolux
L I G H T I N G

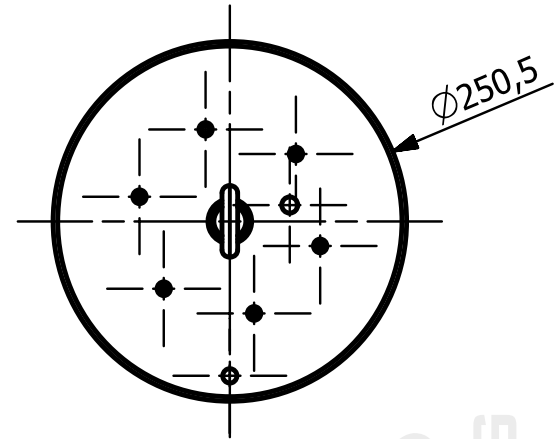

Model No. MLL 906 MI AB Dual

MEDIUM INTENSITY AVIATION OBSTRUCTION LIGHT

SALIENT FEATURES

- ICAO Type AB Compliant
- Dual System : When lower level light fails, system transfer to top level stand by light
- Horizontal Beam Spread 360°/Vertical Beam Spread 4°
- Protection: Weather proof IP 66
- Material of Base : Cast aluminum (LM 6)
- Glass : 6mm Borosilicate Clear Glass
- Gasket: Silicone
- Light source: White LED for Day & Red LED for Night with special optics
- Light Intensity : 20000 CD at Day for White Light & 2000 CD at Night for Red Light
- GPS Flash Sync available on request
- Input Voltage : 85-290V AC or 24V - 60V DC (as per customer requirement)
- Output Voltage : 24V DC
- Wattage – 150W White Light, 30W Red Light
- Approx life of around 50000 hrs
- Earthing Terminal: Provided.
- Paint: Grey/Orange/Yellow (Epoxy Powder Coated)
- Flashing - Inbuilt or through seperate control panel
- Photosensor - Inbuilt for automatic control or seperate
- Fault Alarm - On customer request (2 seperate potential free contact for low level & toplevel)
- Lamp Unit Weight : 16.0 kg.
- Separate Junction Box for wiring.

Micolux
L I G H T I N G

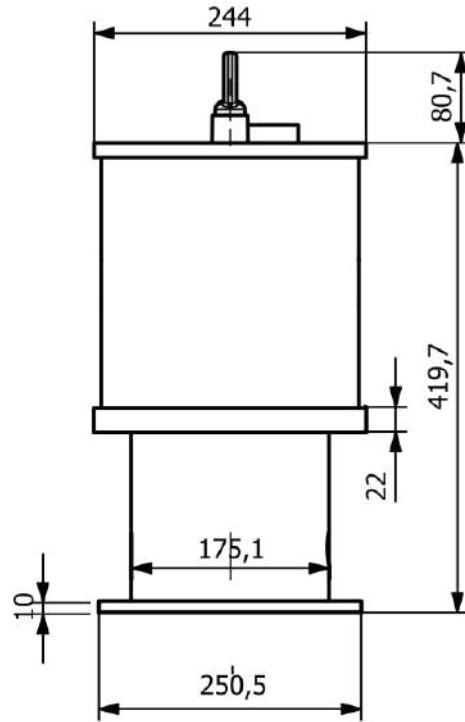

Micolux
L I G H T I N G

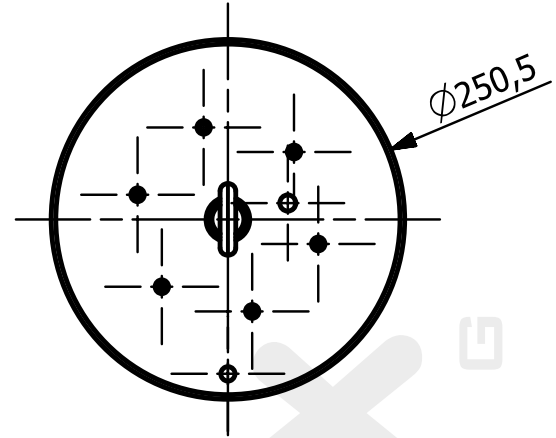

Model No. MLL 907 HI

HIGH INTENSITY AVIATION OBSTRUCTION LIGHT

SALIENT FEATURES

- ICAO Type A & B Compliant
- Horizontal Beam Spread 360°/Vertical Beam Spread 4°
- Protection: Weather proof IP 65
- Easy to install
- Material of construction: Cast aluminum (LM 6)
- Glass : Borosilicate Clear Glass
- Gasket: Silicone.
- Light source: High bright Cree LED's with lens
- Light Intensity : 200000 CD \pm 25% Day mode white flashing
20000 CD \pm 25% Twilight mode white flashing
- 2000 CD \pm 25% Night mode white flashing
- GPS Sync / GSM available on request
- Input Voltage : 85-290V AC or 24V DC with separate Control panel
- Average Power Consumption – 320W
- Approx life of around 50000 hrs
- Earthing Terminal: Provided.
- Paint: Grey (Epoxy Powder Coated)
- Alarm / Remote status control
- Lamp Unit Weight : 20.00 kg.
- Separate Junction Box for wiring.

Micolux
L I G H T I N G



Model No. MLL 907 HI WM

HIGH INTENSITY AVIATION OBSTRUCTION LIGHT

SALIENT FEATURES

- ICAO Type A & B Compliant
- Horizontal Beam Spread 120°/Vertical Beam Spread 4°
- Protection: Weather proof IP 65
- Easy to install
- Material of construction: Cast aluminum (LM 6)
- Glass : Borosilicate Clear Glass
- Gasket: Silicone.
- Light source: High bright Cree LED's with Special Optics
- Light Intensity : 200000 CD \pm 25% Day mode white flashing
20000 CD \pm 25% Twilight mode white flashing
2000 CD \pm 25% Night mode, white flashing
- GPS Sync / GSM available on request
- Input Voltage : 85-290V AC / 12V / 24V / 48V DC can withstand high voltage fluctuations (through separate control panel)
- Average Power Consumption – 500W
- Approx life of around 50000 hrs
- Earthing Terminal: Provided.
- Anodized Coated Housing
- Type dual AB : White Flashing on day & Twilight, Red Flashing on Night
- Type Dual AC : White Flashing on day & Twilight, Red Steady on Night
- Alarm / Remote status control
- Lamp Unit Weight : 14.00 kg.

Micolux
L I G H T I N G



Model No. MLL 906 MI Red WM

MEDIUM INTENSITY AVIATION OBSTRUCTION LIGHT

SALIENT FEATURES

- ICAO Type B & C Compliant
- Horizontal Beam Spread 120°/Vertical Beam Spread 4°
- Protection: Weather proof IP 65
- Material of Base : Cast aluminum (LM 6)
- Glass : Borosilicate Clear Glass
- Gasket: Silicone
- Light source: High bright Cree LED's with Special Optics
- Light Intensity : 3000 CD \pm 25%
- GPS Sync / GSM available on request
- Input Voltage : 85-290V AC or 12V - 60V DC
- Output Voltage : 24V DC
- Wattage – 30W
- Approx life of around 50000 hrs
- Earthing Terminal: Provided.
- Anodized Coated Housing
- Photosensor - Seperate in IP65 box
- Fault Alarm - Can be done on customer request
- Lamp Unit Weight : 4.0 kg.
- Operated through control panel

Micolux
L I G H T I N G



Model No. MLL 906 MI White WM

MEDIUM INTENSITY AVIATION OBSTRUCTION LIGHT

SALIENT FEATURES

- ICAO Type A, AB, AC Compliant
- Horizontal Beam Spread 120°/Vertical Beam Spread 4°
- Protection: Weather proof IP 65
- Material of Base : Cast aluminum (LM 6)
- Glass : Borosilicate Clear Glass
- Gasket: Silicone
- Light source: High bright Cree LED's with Special Optics
- Light Intensity : 3000 CD \pm 25%
- GPS Sync / GSM available on request
- Input Voltage : 85-290V AC or 12V - 60V DC
- Output Voltage : 24V DC
- Wattage – 80W
- Approx life of around 50000 hrs
- Earthing Terminal: Provided.
- Anodized Coated Housing
- Photosensor - Seperate in IP65 box
- **Type Dual AB : White Flashing on day, Red Flashing on Night (Optional)**
- **Type Dual AC : White Flashing on day & Red Steady on Night (Optional)**
- Fault Alarm - Can be done on customer request
- Lamp Unit Weight : 8.0 kg.
- Operated through control panel

Micolux
L I G H T I N G

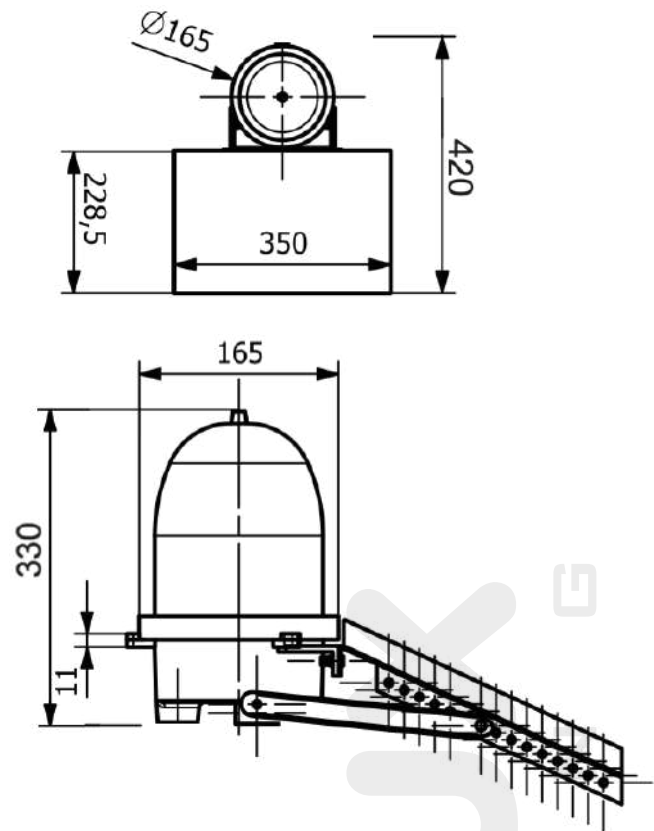

Model No. MLL 904-1 MI Solar

SOLAR MEDIUM INTENSITY AVIATION LIGHT

SALIENT FEATURES

- ICAO Type B Compliant
- Medium Intensity Obstruction Light (Single Dome & Dual Dome)
- Gives omni directional light
- Protection: Weather proof IP 66
- Material of construction: Cast aluminum (LM 6)
- Glass Type : Polycarbonate Red Dome
- Gasket: Silicone
- Light source: High Bright LED's with Special optics
- Light Intensity : 2000 CD \pm 20%
- Wattage : 6W Flashing
- Flashing (Inbuilt) 20 FPM
- Battery used : LFP 3.2V 18AH (Battery Backup 48-50 Hrs. on full charge)
- Solar Module : 12W
- Solar Charge controller – Inbuilt
- Solar Panel can be connected with light using given connector.
- Approx Unit Weight : 5.0 kg.
- Adjustable Solar Panel

Micolux LIGHTING

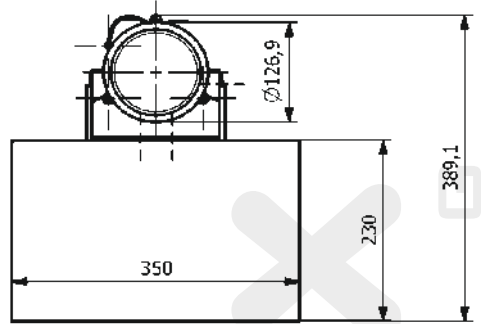
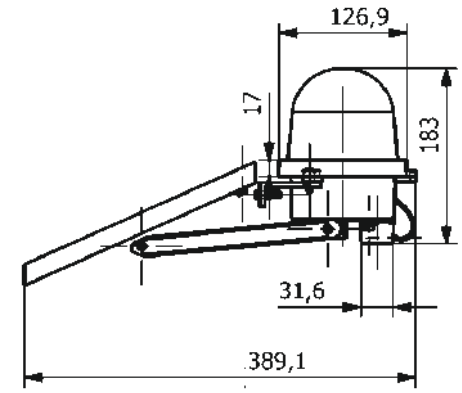

Model No. MLL 904-1 SLI Solar

SOLAR LOW INTENSITY AVIATION OBSTRUCTION LIGHT

SALIENT FEATURES

- ICAO Type A & B Compliant
- Medium Intensity Obstruction Light (Single Dome & Dual Dome)
- Gives omni directional light
- Protection: Weather proof IP 66
- Material of construction: Cast aluminum (LM 6)
- Glass Type : Polycarbonate Red Dome
- Gasket: Silicone
- Light source: High Bright LED's with Special optics
- Light Intensity : 10 cd or 32 Cd (as per customer requirement)
- Wattage : 0.4W
- Flashing – No
- Battery used : LFP 3.2V 6.6AH (Battery Backup 40-49 Hrs. on full charge)
- Solar Module : 9V 12W
- Solar Charge controller – Inbuilt
- Solar Panel can be connected with light using given connector.
- Approx Unit Weight : 3.0 kg.
- Adjustable Solar Panel

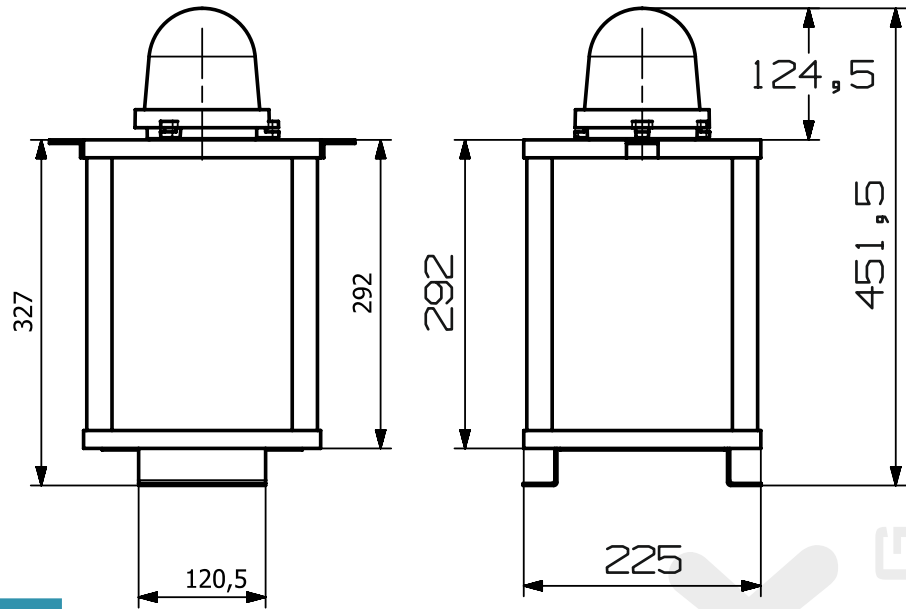

Model No. MLL 909 SLI

SINGLE & DUAL DOME LOW INTENSITY AVIATION LIGHT

SALIENT FEATURES

- ICAO Type A & B Compliant
- Single dome & Dual dome Low Intensity Obstruction Light
- Gives omni directional light
- Protection: Weather proof IP 66
- Material of construction: Cast aluminum (LM 6)
- Glass Type : Polycarbonate Red Dome
- Gasket: Silicone
- Light source: 88 Nos High Bright LED's
- Light Intensity : 10 cd for Type A & 32 Cd for Type B
- Wattage : 1W
- Flashing – No (steady Burning)
- Battery used : LFP 12.8V 12AH (Battery Backup 48-50 Hrs. on full charge)
- Solar Module : 7.5W X 4 Panels
- Solar Charge controller – MPPT charger Inbuilt
- Alarm – Yes (if required)
- Approx Unit Weight : 7.0 kg.

Micolux
L I G H T I N G

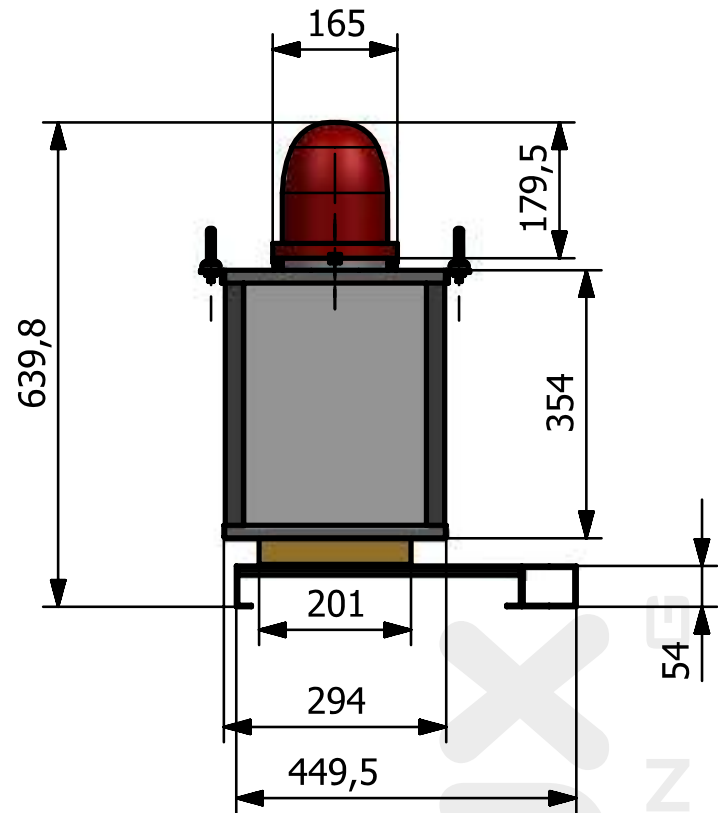

Model No. MLL 909 MI / DMI

SINGLE & DUAL DOME MEDIUM INTENSITY AVIATION LIGHT

SALIENT FEATURES

- ICAO Type B Compliant
- Single dome & Dual dome Medium Intensity Obstruction Light
- Gives omni directional light
- Protection: Weather proof IP 66
- Material of construction: Cast aluminum (LM 6)
- Glass Type : Polycarbonate Red Dome
- Gasket: Silicone
- Light source: High Bright LED's with Special optics
- Light Intensity : 2000 CD \pm 20%
- Wattage : 11W Flashing
- Flashing (Inbuilt) 20 FPM (0.2 Sec On / 2.8 Sec Off)
- Battery used : LFP 12.8V 12AH (Battery Backup 70-75 Hrs. on full charge)
- Solar Module : 12W X 4 Panels
- Solar Charge controller – MPPT charger Inbuilt
- Alarm – Yes (if required)
- Approx Unit Weight : 13.0 kg.

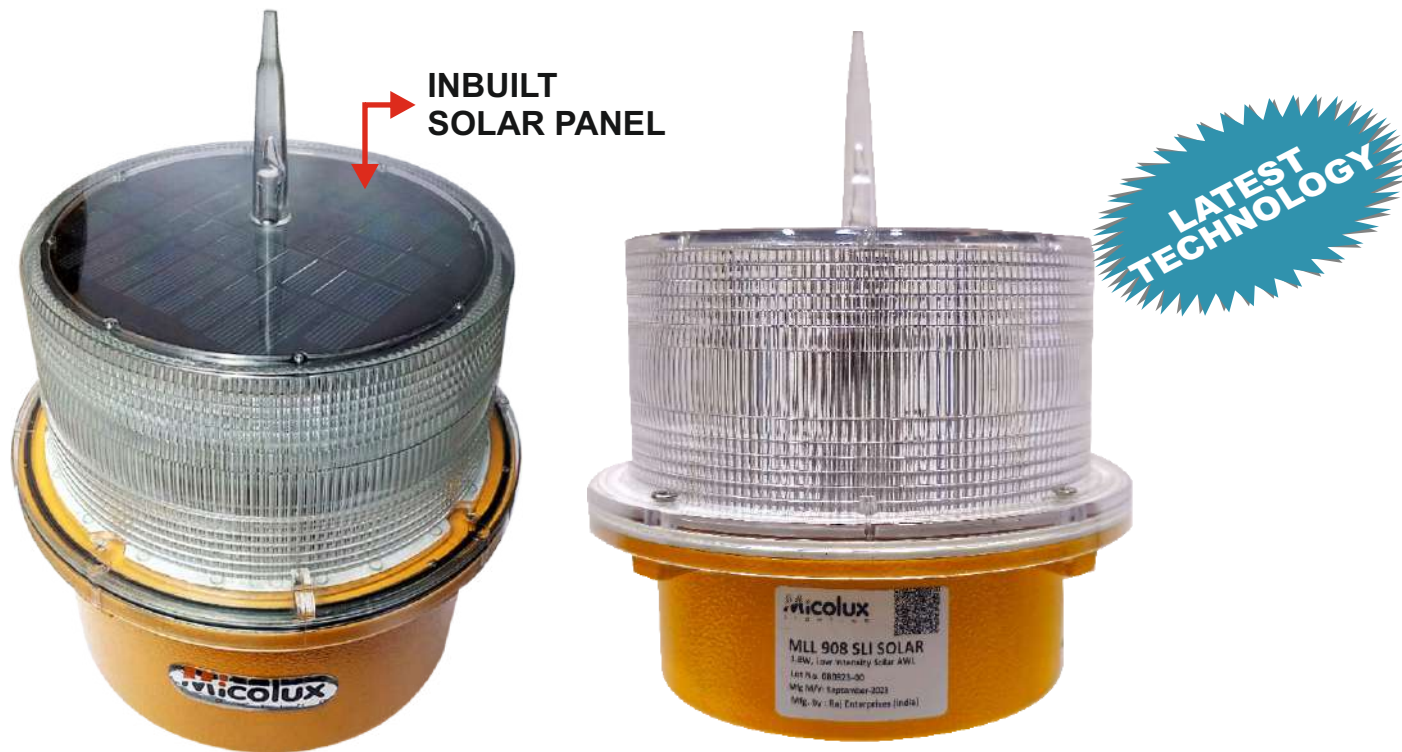

Model No. MLL 908 SLI

COMPACT SOLAR AVIATION OBSTRUCTION LIGHT

Description	Parameter	Description	Parameter
Light source	8 ultra-high intensity LEDs	Battery capacity	3.6V/6AH/12AH (On Request)
Intensity	>10cd (flashing)	Solar Panel	1.8W
Horizontal divergence	360°	Ambient temperature	-20°C~ +80°C
Vertical divergence	3°	IP Protection	IP66
LED lifetime	100,000 hrs	Autonomy	>200 hrs
Flash settings	20 ~ 60 times/min	Weight	2.3Kg
On/off level	70/100 Lux	Mounting	177mm (Dr) * 238mm(H)
Solar module type	Monocrystalline	Visible distance	>3.6Km (atmospheric transparency=0.85)

FUNCTIONS & FEATURES

- Based on LED technology
- Aviation red type
- Base material-- Die casting aluminum LM6
- Lamp housing -- Polycarbonate with UV resistance
- Bird spike
- Built-in photocell
- Steel wire is used to connect base to housing against falling in operation
- Built in LifePO4 battery, easy for replacement
- No RF-radiations, EMC compliant
- Shockproof and corrosion resistance
- Extremely Reliable -- Major maintenance cost saving
- Very low power consumption -- Low energy cost

Model No. MLL 48V AWL DB

CONTROL PANEL

SALIENT FEATURES

- Weather Protection - IP65
- Gasket used - Silicone
- Voltage – 40-75V DC
- 16 Amp MCB – 2 Pole
- 32 Amp Surge Protection – 10KVA, SPD type2
- Fault Alarm Yes.
- Enclosure materials Galvanized iron (GI)
- Control Cabinet Dimension : 305x340x180mm
- Weight : 8Kg.



Model No. MLL 910 BFD LED

BIRD FLIGHT DIVERTER

SALIENT FEATURES

- Universal Clamp for mounting between 10mm wire to 38mm wire.
- Used on communication towers & power lines.
- Glow in Dark
- > 3500 mm² reflective area on each face of warning disc, Glow in Dark
- UV stabilized plastic.
- LED Orange colour with adequate light intensity
- Battery backup 100 hrs of flashing operation by single charge.
- Automatic power cut-off electronics circuit in day time.
- The circuit switches on automatically under low intensity light condition.
- Corrosion free & strong material with special bearing for Spinning in minimum wind speed of 2 km/hour. Low air pressure helps in rotation & survival movement
- The clamp temperature ranges from -15°C to +85°C
- Clamp Slip /Grip Retaining Strength > 25 kg force
- Pulling load > 50 kgs

Model No. MLL 910 BFD NON-LED

BIRD FLIGHT DIVERTER

SALIENT FEATURES

- Universal Clamp for mounting between 10mm wire to 38mm wire.
- Used on communication towers & power lines.
- > 3500 mm² reflective area on each face of warning disc,
- Glow in Dark
- UV stabilized Material used
- Corrosion free & strong material with special bearing for Spinning in minimum wind speed of 2 km/hour.
- Clamp Slip /Grip Retaining Strength > 25 kg force.
- Low air pressure helps in rotation & survival movement
- The clamp temperature ranges from -15°C to +85°C
- Pulling load > 50 kgs
- BFD Weight < 800 gms





Model No. MLL DL 30W

NON EMERGENCY INDOOR TOWER LIGHT

SALIENT FEATURES

Non Emergency Indoor Tower Light IP65

- Input Voltage 120-277V AC / 50-60 Hz.
- Wattage - 30 / Lumen - 2800 lm
- Non Emergency indoor tower LED light
- Weather Protection - IP65
- Gasket used - Silicone
- LED Technology lasts upto 50,000 Hrs
- Housing material - Polycarbonate diffuser & Aluminum Section & Clamp
- Operating Temp - 10° to +60° Degree
- IP68 M25 Quick Gland Connector for Hassle Free wiring connection

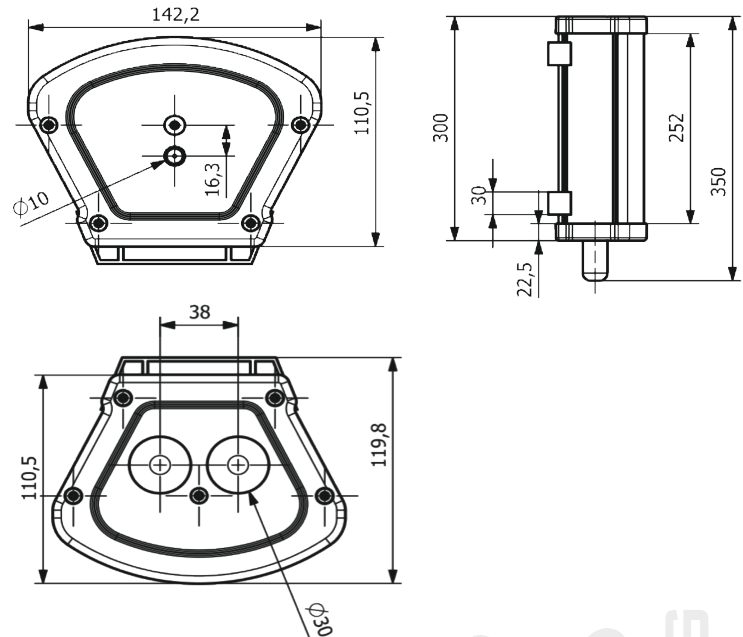

WIND TURBINE TOWER LIGHT

Model No. MLL EL 30W

EMERGENCY LED LIGHTS IP65

SALIENT FEATURES

Emergency LED Light IP65

- Input Voltage 120-277V AC, 50-60Hz.
- Wattage - 30W/Lumen 2800
- Emergency Indoor Tower LED Light
- Weather Protection - IP65
- Gasket used - Silicone
- Light Switching time is less than 1 Second
- Light Turn on Time is less than 1 second
- LED Technology lasts upto 50,000 Hrs
- Battery Over & Under charge protection
- Housing material - Polycarbonate diffuser & Aluminum section & clamp
- Maximum Charging time - 24 Hrs., Power Backup 90 minutes
- LED indication available for charging & Light
- Emergency Mode - Light switch to 5W with lumen of > 500
- Operating Temp -10° to +60° Degree
- IP68 M25 Quick Gland Connector for Hassle Free wiring connection
- Auto Test Button for reducing Maintenance Cost & Testing Light
- Lithium Ion Battery used for better working

Model No. MLL 906 DB-1

CONTROL PANEL FOR WIND TURBINE AVIATION LIGHT SYSTEM

SALIENT FEATURES

- Input Voltage - 90-290V AC, 50-60Hz
- Dual power supply to work 2 lights
- Smart microcontroller to manage working complete system.
- GPS Synchronization
- 10 KVA Surge protection type 25 PD
- IP68 Power supply
- IP54 Control panel
- Easy wiring.
- Working : Day time white / Night time Red.
- Fault Alarm - Inbuilt for remote monitoring.
- Dimension - 700 x 500 x 100mm
- Enclosure material - Powder Coated G1 Sheet
- Weight - 20Kg.



Model No. MLL 906 UPS SW

1 KVA SIEN WAVE UPS

SALIENT FEATURES

- Rated Power - 800 Watt - 900 Watt / 1000VA
- Operating Voltage 100-290V AC 50 Hz
- UPS output Voltage - 230V-AC
- Charging Current 8A-10A
- Battery Voltage - 10.5 to 13.5V - DC (VRLA SMF)
- Typic / Transfer Time 10ms - 15ms
- Enclosure materials Galvanized iron (GI)
- UPS Cabinet dimension - 500x500x300mm
- IP54 Panel
- Weight - 45Kg (Including Battery)
- Weather protection - IP54
- Warranty - 1 Year



LED TRI-PROOF LIGHT

High quality construction



Product details

Focus on product details to better improve overall performance and improve product quality



Model No.	Voltage	Wattage	Color Temp	Lumen	Emergency Mode
MLL DL 20W	100-285V	20W	2800K / 6500K	1700	No
MLL EL 20W	100-285V	20W	2800K / 6500K	1700	Yes, 90 Minutes
MLL DL 30W	100-285V	30W	2800K / 6500K	2600	No
MLL EL 30W	100-285V	30W	2800K / 6500K	2600	Yes, 90 Minutes

Note : Can be customised on customer requirement in plastic inclosure.

Performance

LED
SHARP®

AC
230VAC

IRC
>80



CLASS II

IP65



2 Year
Warranty

Product Application



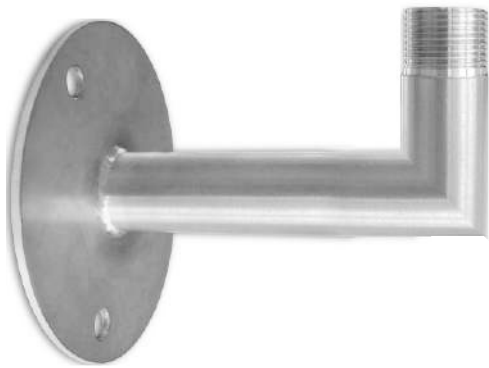

Model No. MLL 101
WALL MOUNTING BRACKET



Model No. MLL 107
TOP MOUNTING BRACKET

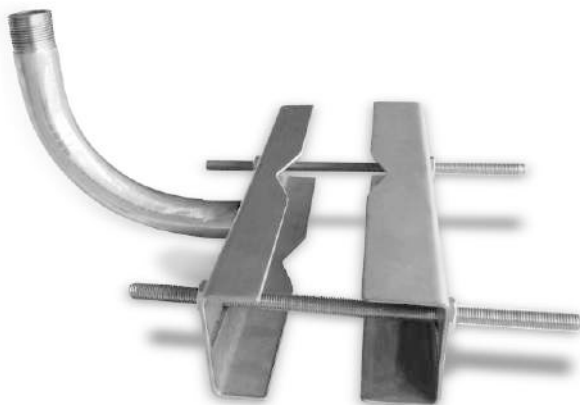

Model No. MLL 103
POLE MOUNTING BRACKET



Model No. MLL 102
TOP MOUNTING BRACKET



LED STREET LIGHT

Model No.	Voltage	Wattage	Color Temp	Lumen	LED Used
MLL115	100-285V AC	15W	2800K / 6500K	1500	Power LED
MLL125	100-285V AC	25W	2800K / 6500K	2500	Power LED
MLL130	100-285V AC	30W	2800K / 6500K	2500	Power LED
MLL140	100-285V AC	40W	2800K / 6500K	4000	Power LED
MLL160	100-285V AC	60W	2800K / 6500K	6000	Power LED
MLL190	100-285V AC	90W	2800K / 6500K	9000	Power LED
MLL1120	100-285V AC	120W	2800K / 6500K	12000	Power LED
MLL1150	100-285V AC	150W	2800K / 6500K	15000	Power LED
MLL1200	100-285V AC	200W	2800K / 6500K	20000	Power LED

LED UFO LIGHT

Model No.	Voltage	Wattage	Color Temp	Lumen
MLL250	100-285V AC	50W	2800K / 6500K	5000
MLL2100	100-285V AC	100W	2800K / 6500K	10000
MLL2150	100-285V AC	150W	2800K / 6500K	15000
MLL2200	100-285V AC	200W	2800K / 6500K	20000



LED FLOOD LIGHT

Model No.	Voltage	Wattage	Color Temp	Lumen	LED Used
MLL320	100-285V AC	20W	2800K / 6500K	2000	Power LED
MLL330	100-285V AC	30W	2800K / 6500K	3000	Power LED
MLL350	100-285V AC	50W	2800K / 6500K	5000	Power LED
MLL370	100-285V AC	70W	2800K / 6500K	7000	Power LED
MLL3100	100-285V AC	100W	2800K / 6500K	10000	Power LED
MLL3120	100-285V AC	120W	2800K / 6500K	12000	Power LED
MLL3150	100-285V AC	150W	2800K / 6500K	15000	Power LED
MLL3180	100-285V AC	180W	2800K / 6500K	18000	Power LED
MLL3200	100-285V AC	200W	2800K / 6500K	20000	Power LED



LED FLOOD LIGHT with PIR Sensor

Model No.	Voltage	Wattage	Color Temp	Lumen	LED Used
MLL570 IR	100-285V AC	50W	2800K / 6500K	4500	Power LED
MLL5100	100-285V AC	100W	2800K / 6500K	9500	Power LED

10W-12W Solar Integrated Street Light

Model No.	: MLL 10SL
Wattage	: 10W to 12W
Lumen	: 1000
Solar Panel	: 10W Monocrystalline
Solar Panel Efficiency	: 18%
Solar Charge Controller	: Inbuilt
Battery	: 3.6V 20 Ah, LifePO (2000 Cycle)
Battery Backup	: - If No Movement 20 Hrs at 25% Light - If Movement 8 Hrs at 100% light
Motion Sensor	: Inbuilt
Working	: Automatic
Weather Protection	: IP65
Light Distribution	: Type 2 Lens (60 Degree / 120 Degree)
Led Chip Used	: Everlite
Weight	: 1.5 KG



18W-20W Solar Integrated Street Light

Model No.	: MLL 20SL
Wattage	: 18W to 20W
Lumen	: 1600
Solar Panel	: 15W Monocrystalline
Solar Panel Efficiency	: 18%
Solar Charge Controller	: Inbuilt
Battery	: 7.2V 20 Ah, LifePO (2000 Cycle)
Battery Backup	: - If No Movement 20 Hrs at 25% Light - If Movement 8 Hrs at 100% light
Motion Sensor	: Inbuilt
Working	: Automatic
Weather Protection	: IP65
Light Distribution	: Type 2 Lens (60 Degree / 120 Degree)
Led Chip Used	: Everlite
Weight	: 2.5 KG



25W to 30W Solar Integrated Street Light

Model No.	: MLL 30SL
Wattage	: 25W to 30W
Lumen	: 2400
Solar Panel	: 22W Monocrystalline
Solar Panel Efficiency	: 18%
Solar Charge Controller	: Inbuilt
Battery	: 10.8V 20 Ah, LifePO (2000 Cycle)
Battery Backup	: - If No Movement 20 Hrs at 25% Light - If Movement 8 Hrs at 100% light
Motion Sensor	: Inbuilt
Working	: Automatic
Weather Protection	: IP65
Light Distribution	: Type 2 Lens (60 Degree / 120 Degree)
Led Chip Used	: Everlite
Weight	: 3.5 KG



A COMPLETE SETS OF AVIATION LIGHTS ON WIND TURBINE

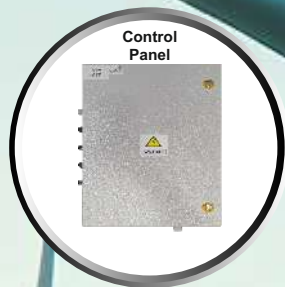



🏠 B-67/2, NARAINA INDUSTRIAL AREA, PHASE-2, NEW DELHI-110028 (INDIA)
🌐 www.micoluxlighting.com ✉ info@micoluxlighting.com ☎ +91-11-45056806

